



### Features

- 2.2V Start-up Input Voltage
- 10V@1A (VIN = 3.3V)  
21V@700mA (VIN = 5V)
- Input Voltage: 2.2V ~ 5V
- Output Voltage: 2.5V ~ 21V
- Up to 90% Efficiency
- Providing Flexibility for Using Internal and External Power Switches
- SOP-8L Package

### Applications

- PDA
- DSC
- LCD Panel
- RF-Tags
- MP3
- Portable Instrument
- Wireless Equipment

### Description

The HX3134A is a compact, high efficiency, and low voltage step-up DC/DC converter with an Adaptive Current Mode PWM control loop, includes an error amplifier, ramp generator, comparator, switch pass element and driver in which providing a stable and high efficient operation over a wide range of load currents. It operates in stable waveforms without external compensation.

HX3134A can operate from an input voltage as low as 2.2V. HX3134A can generate 21V up to 700mA from a 5V supply.

The HX3134A is available in a low profile SOP-8L package.

## Typical Application Circuit

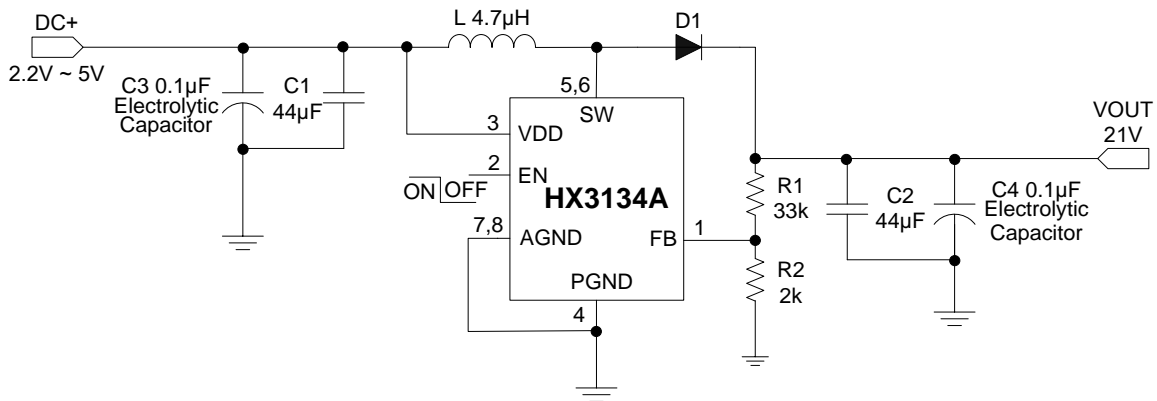

\*  $V_{OUT} = 1.212V \cdot [1 + (R1/R2)]$ .

## Pin Assignment and Function

TOP VIEW		PIN	NAME	FUNCTION
		1	FB	Feedback
		2	EN	Logic Control (High Enable)
		3	VDD	Output Voltage Sense Input
		4	PGND	Power Ground No Connect
		5,6	SW	Switch Pin
		7,8	AGND	Analog Ground

## Absolute Maximum Ratings (Note 1)

- Supply Voltage..... -0.3V ~ 6.5V
- SW Pin Switch Voltage.....-0.3V ~ 22V
- Other I/O Pin Voltages.....-0.3V ~ (VDD + 0.3V)
- SW Pin Switch Current .....5A
- Operating Temperature Range(Note 2).....-40□ ~ +85□
- Junction Temperature.....-40□ ~ +125□
- Storage Temperature Range .....-65°C ~ +150□
- Lead Temperature (Soldering 10sec)... ..+265□

**Note 1:** Stresses beyond those listed Absolute Maximum Ratings may cause permanent damage to the device.

Exposure to any Absolute Maximum Rating condition for extended periods may affect device reliability and lifetime.

**Note2:** The HX3134A is guaranteed to meet performance specifications from 0□ to 70□ . Specifications over the -40□ to 85□ operating temperature range are assured by design, characterization and correlation with statistical process controls.

## Electrical Characteristics

Operating Conditions:  $T_A=25^\circ\text{C}$ ,  $V_{IN}=5\text{V}$ ,  $V_{OUT}$  set to 21V, unless otherwise specified.

SYMBOL	PARAMETER	CONDITIONS	MIN	TYP	MAX	UNITS
$V_{START}$	Start-up Voltage	$I_{OUT} = 1\text{mA}$		2.2		V
VDD	Operating VDD Range	VDD Pin Voltage	2.2		5	V
$I_Q$	Supply Current (Quiescent)	$V_{FB} = 1.2\text{V}$		1300		$\mu\text{A}$
$I_{SHDN}$	Supply Current (Shutdown)	$EN = 0\text{V}$			40	$\mu\text{A}$
$V_{FB}$	Feedback Reference Voltage		1.188	1.212	1.236	V
$I_{FB}$	FB Pin Current			0.1		$\mu\text{A}$
$f_{OSC}$	Switching Frequency	$I_{OUT} = 500\text{mA}$		400		kHz
DC	Maximum Duty			90		%
$R_{ON}$	SW ON Resistance			100		m $\Omega$
$V_{ENH}$	EN High Threshold	$V_{EN}$ Rising	0.8			V
$V_{ENL}$	EN Low Threshold				0.6	V
$I_{EN}$	EN Input Bias Current	$V_{EN} = 0\text{V}, 5\text{V}$		55		$\mu\text{A}$

## Typical Performance Characteristics

Operating Conditions:  $T_A=25^{\circ}\text{C}$ , unless otherwise specified.

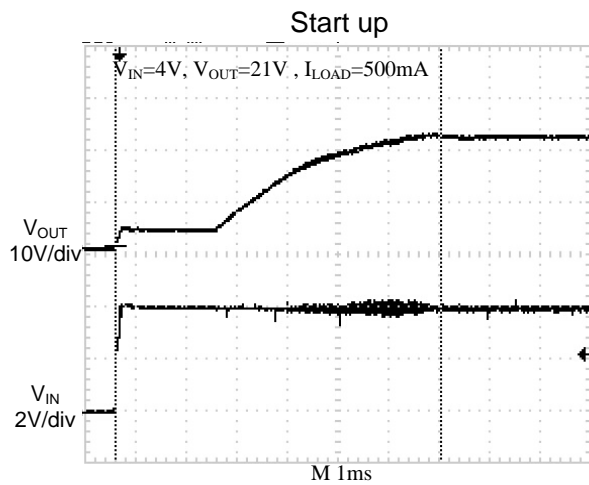
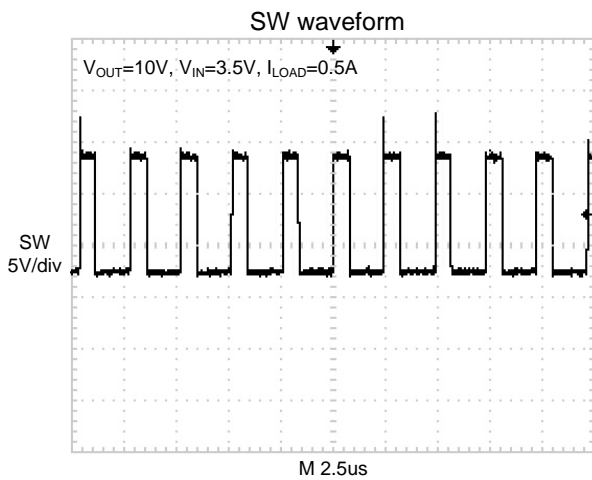
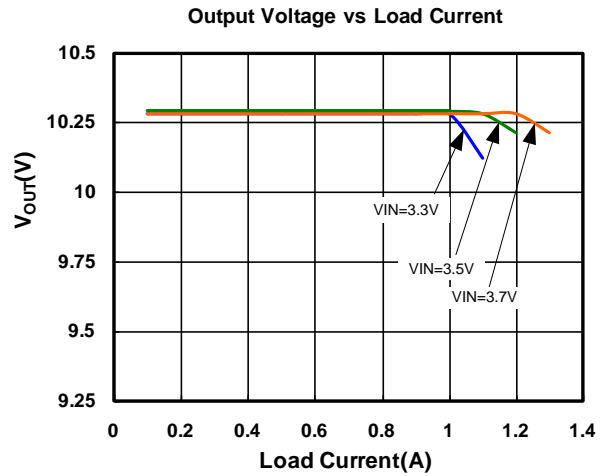
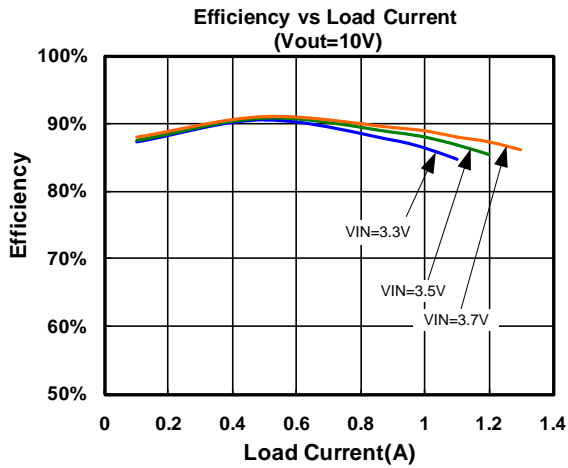

## Pin Information

**FB (Pin 1):** Feedback Input to the  $g_m$  Error Amplifier. Connect resistor divider tap to this pin.

**EN (Pin 2):** Logic Controlled Shutdown Input. EN=High: Normal free running operation. EN=Low: Shutdown.

**VDD (Pin 3):** Output Voltage Sense Input. The NMOS switch gate drive is derived from the greater of  $V_{OUT}$  and  $V_{IN}$ .

**PGND (Pin 4):** Power Ground.

**SW (Pin 5, 6):** Switch Pin. Connect inductor between SW and VIN. Keep these PCB trace lengths as short and wide as possible to reduce EMI and voltage overshoot.

**AGND (Pin 7, 8):** Analog Ground.

## Application Information

### Inductor Selection

For most applications, the value of the inductor will fall in the range of 1 $\mu$ H to 4.7 $\mu$ H. Its value is chosen based on the desired ripple current. Large value inductors lower ripple current and small value inductors result in higher ripple currents. Higher  $V_{IN}$  or  $V_{OUT}$  also increases the ripple current as shown in equation .A reasonable starting point for setting ripple current is  $I_L = 0.72A$  (40% of 1.8A).

$$\Delta I_L = \frac{1}{(f)(L)} V_{OUT} \left( 1 - \frac{V_{OUT}}{V_{IN}} \right)$$

The DC current rating of the inductor should be at least equal to the maximum load current plus half the ripple current to prevent core saturation. Thus, a 2.16A rated inductor should be enough for most applications (1.8A + 0.36A). For better efficiency, choose a low DC-resistance inductor.

Different core materials and shapes will change the size/current and price/current relationship of an inductor. Toroid or shielded pot cores in ferrite or perm alloy materials are small and don't radiate much energy, but generally cost more than powdered iron core inductors with similar electrical characteristics. The choice of which style inductor to use often depends more on the price vs. size requirements and any radiated field/EMI requirements than on what  $V_{OUT}$  requires to operate.

### Output and Input Capacitor Selection

In continuous mode, the source current of the top MOSFET is a square wave of duty cycle  $V_{OUT}/V_{IN}$ . To prevent large voltage transients, a low ESR input capacitor sized for the maximum RMS current must be used. The maximum RMS capacitor current is given by:

$$C_{IN} \text{ required } I_{RMS} \cong I_{OMAX} \frac{[V_{OUT}(V_{IN} - V_{OUT})]^{1/2}}{V_{IN}}$$

This formula has a maximum at  $V_{IN} = 2V_{OUT}$ , where  $I_{RMS} = I_{OUT}/2$ . This simple worst-case condition is commonly used for design because even significant deviations do not offer much relief. Note that the capacitor manufacturer's ripple current ratings are often based on 2000 hours of life. This makes it advisable to further derate the capacitor, or choose a capacitor rated at a higher temperature than required. Always consult the manufacturer if there is any question.

The selection of  $C_{OUT}$  is driven by the required effective series resistance (ESR). Typically, once the ESR requirement for  $C_{OUT}$  has been met, the RMS current rating generally far exceeds the  $I_{RIPPLE(P-P)}$  requirement. The output ripple  $\Delta V_{OUT}$  is determined by:

$$\Delta V_{OUT} \cong \Delta I_L \left( ESR + \frac{1}{8fC_{OUT}} \right)$$

Where  $f$  = operating frequency,  $C_{OUT}$  = output capacitance and  $\Delta I_L$  = ripple current in the inductor. For a fixed output voltage, the output ripple is highest at maximum input voltage since  $\Delta I_L$  increases with input voltage.

Aluminum electrolytic and dry tantalum capacitors are both available in surface mount configurations. In the case of tantalum, it is critical that the capacitors are surge tested for use in switching power supplies. An excellent choice is the AVX TPS series of surface mount tantalum. These are specially constructed and tested for low ESR.

## Efficiency Considerations

The efficiency of a switching regulator is equal to the output power divided by the input power times 100%. It is often useful to analyze individual losses to determine what is limiting the efficiency and which change would produce the most improvement. Efficiency can be expressed as: Efficiency = 100% - (L1+ L2+ L3+ ...) where L1, L2, etc. are the individual losses as a percentage of input power. Although all dissipative elements in the circuit produce losses, two main sources usually account for most of the losses: VIN quiescent current and I<sup>2</sup>R losses. The VIN quiescent current loss dominates the efficiency loss at very low load currents whereas the I<sup>2</sup>R loss dominates the efficiency loss at medium to high load currents. In a typical efficiency plot, the efficiency curve at very low load currents can be misleading since the actual power lost is of no consequence.

1. The VIN quiescent current is due to two components: the DC bias current as given in the electrical characteristics and the internal main switch and synchronous switch gate charge currents. The gate charge current results from switching the gate capacitance of the internal power MOSFET switches. Each time the gate is switched from high to low to high again, a packet of charge  $\Delta Q$  moves from VIN to ground. The resulting  $\Delta Q/\Delta t$  is the current out of VIN that is typically larger than the DC bias current. In continuous mode,  $I_{GATECHG} = f(Q_T + Q_B)$  where  $Q_T$  and  $Q_B$  are the gate charges of the internal top and bottom switches. Both the DC bias and gate charge losses are proportional to VIN and thus their effects will be more pronounced at higher supply voltages.

2. I<sup>2</sup>R losses are calculated from the resistances of the internal switches, R<sub>SW</sub> and external inductor R<sub>L</sub>. In continuous mode the average output current flowing through inductor L is “chopped” between the main switch and the synchronous switch. Thus, the series resistance looking into the SW pin is a function of both top and bottom MOSFET R<sub>DS(ON)</sub> and the duty cycle (DC) as follows:  $R_{SW} = R_{DS(ON)TOP} \times DC + R_{DS(ON)BOT} \times (1-DC)$  The R<sub>DS(ON)</sub> for both the top and bottom MOSFETs can be obtained from the Typical Performance Characteristics curves. Thus, to obtain I<sup>2</sup>R losses, simply add R<sub>SW</sub> to R<sub>L</sub> and multiply the result by the square of the average output current. Other losses including C<sub>IN</sub> and C<sub>OUT</sub> ESR dissipative losses and inductor core losses generally account for less than 2% of the total loss.

## Board Layout Suggestions

When laying out the printed circuit board, the following checklist should be used to ensure proper operation of the HX3134A. Check the following in your layout.

1. The power traces, consisting of the GND trace, the SW trace and the VIN trace should be kept short, direct and wide.
2. Put the input capacitor as close as possible to the device pins (VIN and GND).
3. SW node is with high frequency voltage swing and should be kept small area. Keep analog components away from SW node to prevent stray capacitive noise pick-up.
4. Connect all analog grounds to a command node and then connect the command node to the power ground behind the output capacitors.

## Packaging Information

### SOP-8L Package Outline Dimension

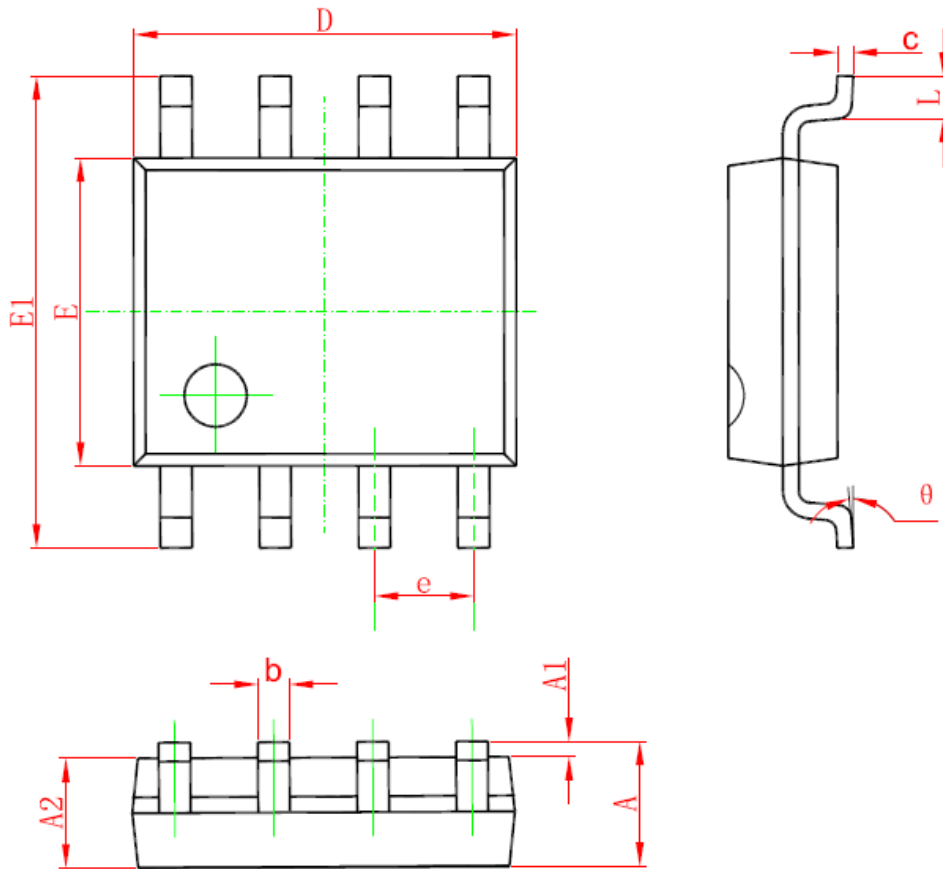

Symbol	Dimensions In Millimeters		Dimensions In Inches	
	Min	Max	Min	Max
A	1.350	1.750	0.053	0.069
A1	0.100	0.250	0.004	0.010
A2	1.350	1.550	0.053	0.061
b	0.330	0.510	0.013	0.020
c	0.170	0.250	0.006	0.010
D	4.700	5.100	0.185	0.200
E	3.800	4.000	0.150	0.157
E1	5.800	6.200	0.228	0.244
e	1.270(BSC)		0.050(BSC)	
L	0.400	1.270	0.016	0.050
$\theta$	0°	8°	0°	8°

Subject changes without notice.